

1,3-Bis(silyl)cyclodisilazane: synthesis and crystal structure

Bettina Jaschke, Regine Herbst-Irmer, Uwe Klingebiel,* Peter Neugebauer and Thomas Pape

Institut für Anorganische Chemie der Universität, Tammannstr. 4, D-37077 Göttingen, Germany.
E-mail: uklinge@gwdg.de

The reaction between $(\text{Me}_3\text{C})_2\text{MeSiNHLi}$ and SiCl_4 afforded R-NH-SiCl_3 **1**, and $(\text{R-NH})_2\text{SiCl}_2$ **2**; **1** reacted with BuLi with formation of the tetrachlorocyclodisilazane $(\text{RN-SiCl}_2)_2$ **3**, $\text{R} = \text{SiMe}(\text{CMe}_3)_2$, hydrogenation of which with LiAlH_4 resulted in the first cyclodisilazane $(\text{RN-SiH}_2)_2$ **4**.

Compared to cyclosilazanes bearing organic substituents, only very few Si-N ring systems in which some or all of the substituents are inorganic are known.¹⁻⁵ We have reported the first examples of cyclodisilazanes bearing silyl groups at the nitrogen and fluorine substituents at the silicon atoms.^{3,4} These compounds display the opposite structural features to their organic-substituted counterparts, *i.e.* in cyclodisilazanes the Si-N-Si angles are smaller while the N-Si-N angles are larger than 90°, and the observed endocyclic Si-N bonds are shorter than the exocyclic bonds. Theoretical calculations for model compounds demonstrate that fluorination of the parent compound, *i.e.* $(\text{H}_2\text{Si-NH})_2 \longrightarrow (\text{F}_2\text{Si-NH})_2$, leads to shortening of the endocyclic Si-N bonds from 173 to 170 pm and, thus, to stabilisation of the ring system.⁴ Furthermore silylation at the nitrogen atoms leads to a decrease in the endocyclic Si-N-Si angles. The combined effect of the fluorine atoms at the silicon and of two silyl groups at the nitrogen atoms leads to the formation of the “smallest” (Si-N)₂ four-membered ring systems known so far and to an overall shortening of the transannular Si...Si distance. The shortest Si...Si contact has been predicted for $(\text{F}_2\text{Si-NSiH}_3)_2$ (242 pm) and found for $[\text{F}_2\text{Si-NSi}(\text{CMe}_3)_2\text{Ph}]_2$ (237.6 pm). These contacts are equal to or only slightly longer than Si-Si bonds in disilanes.⁵

1,3-Bis(silyl)cyclodisilazanes ($\text{R}_3\text{Si-N-SiH}_2$) are still unknown. We were interested in the structural features of these compounds and report the synthesis and molecular structure of the first cyclodisilazane that bears hydrogen atoms at the silicon and silyl groups at the nitrogen atoms. Knowing the stabilisation effect of bulky silyl groups from the isolation of imino-silanes,⁶ monomeric aminoalanes,⁶ or silyldiazenes,⁷ we used the di-*tert*-butylmethylsilyl group as substituent.

Two routes lead to the formation of the cyclosilazanes (Scheme 1).^{†‡} Lithium di-*tert*-butylmethylsilylamide⁸ reacts with SiCl_4 in a molar ratio 1:1 or 1:0.5 to give the silylamino-trichlorosilane **1** or the bis(silyl)dichlorosilane **2**. In the reaction of **1** with BuLi a lithium derivative is obtained, which is thermally unstable. The cyclodisilazane **3** is formed by LiCl elimination. Ring closure with formation of **3** also occurs in the reaction of the dilithium derivative of **2** and SiCl_4 .

Compound **3** was found to react with LiAlH_4 to give the 1,3-bis(silyl)cyclodisilazane **4**. Fig. 1 shows the crystal structure of **4**.[§] Compound **4** crystallises in the space group $P2_1/c$ with half of a molecule in the asymmetric unit. The sum of the angles around the nitrogen atoms is 359.5°. The ellipsoids of the ring Si atoms showed a long displacement perpendicular to the ring plane. Therefore the SiH_2 group is refined over two positions (Fig. 1 shows the Si- and H-atom position with higher occu-

pancies). This leads to a great unreliability of the bond lengths and angles involved and they should not be discussed.

Standard molecular orbital calculations^{4,11} were carried out for the parent 1,3-cyclodisilazane and the 1,3-bis(silyl)cyclodisilazane, which serve as close models for the synthesised

[†] Preparative details. Compound **1**: Di-*tert*-butylmethylsilylamine (0.5 mol, 86.5 g) in *n*-hexane (350 ml) was metallated with 1 equivalent of *n*-butyllithium (15% in *n*-hexane). The suspension was cooled to 0 °C and added to a solution of tetrachlorosilane (0.5 mol, 84.9 g) in *n*-hexane (100 ml). The mixture was warmed to room temperature and heated to reflux for 1 h. After removal of lithium chloride by filtration (10^{-2} Torr) **1** was purified by distillation *in vacuo* (10^{-2} Torr). Yield 91%, bp 50 °C (0.01 Torr); FI-MS: m/z (%) = 305 (95) $[\text{M}]^+$, EI-MS m/z (%) = 248 (20) $[\text{M} - \text{C}(\text{CH}_3)_3]^+$. Compound **2**: **2** was synthesised like **1**. The molar ratio was 2:1 in this case (0.5 mol, 86.5 g di-*tert*-butylmethylsilylamine, 0.25 mol, 42.5 g tetrachlorosilane), **2** was also purified by distillation. Yield 73%, bp 135 °C (0.01 Torr); EI-MS: m/z (%) = 385 (40) $[\text{M} - \text{C}(\text{CH}_3)_3]^+$. Compound **3**: **1** (80.1 mol, 27.9 g) was dissolved in *n*-hexane (50 ml) and cooled to -10 °C, 1 equivalent of BuLi (15% in *n*-hexane) was added slowly. After stirring for 1 h at -5 °C the reaction mixture was warmed to room temperature. Lithium chloride was filtered off and after removal of the solvent **3** was crystallised in *n*-hexane. Yield 40%, mp 127 °C; FI-MS: m/z (%) = 540 (100) $[\text{M}]^+$, EI-MS: m/z (%) = 483 (35) $[\text{M} - \text{C}(\text{CH}_3)_3]^+$. Compound **4**: a solution of **3** (0.02 mol, 10.8 g) in diethyl ether (50 ml) was slowly added to a suspension of LiAlH_4 (0.02 mol, 0.76 g) in diethyl ether (25 ml). The mixture was heated to reflux for 16 h. After separation from the solid components by filtration **4** was obtained by distillation and crystallisation in *n*-hexane. Yield 42%, mp 96 °C; EI-MS: m/z (%) = 402 (5) $[\text{M}]^+$, 345 (58) $[\text{M} - \text{C}(\text{CH}_3)_3]^+$; IR: $\tilde{\nu} = 2132.7 \text{ cm}^{-1}$ (SiH). The isolated compounds are analytically pure, air stable, but moisture sensitive.

[‡] NMR data: ¹H NMR (CDCl_3 , 250 MHz, SiMe_4), **1**: δ 0.27 (s, SiMe , 3 H), 1.00 (s, SiCMe_3 , 18 H), 1.64 (s, NH, 1 H); ¹³C NMR (CDCl_3 , 250 MHz, SiMe_4), δ -7.83 (s, SiCH_3), 20.16 (s, SiCC_3), 27.70 (s, SiCC_3); ²⁹Si NMR (CDCl_3 , 250 MHz, SiMe_4), δ -24.69 (s, SiCl_3), 12.40 (s, SiC). **2**: ¹H NMR (CDCl_3 , 250 MHz, SiMe_4), δ 0.25 (s, SiMe , 6 H), 0.99 (s, SiCMe_3 , 36 H), 1.25 (s, NH, 2 H); ¹³C NMR (CDCl_3 , 250 MHz, SiMe_4), δ -7.74 (s, SiCH_3), 20.25 (s, SiCC_3), 27.91 (s, SiCC_3); ²⁹Si NMR (CDCl_3 , 250 MHz, SiMe_4), δ -28.53 (s, SiCl_2), 10.25 (s, SiC). **3**: ¹H NMR (CDCl_3 , 250 MHz, SiMe_4), δ 0.31 (s, SiCMe , 6 H), 1.08 (s, SiCMe_3 , 36 H); ¹³C NMR (CDCl_3 , 250 MHz, SiMe_4), δ -5.78 (s, SiCH_3), 20.73 (s, SiCC_3), 28.49 (s, SiCC_3); ²⁹Si NMR (CDCl_3 , 250 MHz, SiMe_4), δ -37.67 (s, SiCl_2), 10.90 (s, SiC). **4**: ¹H NMR (CDCl_3 , 250 MHz, SiMe_4), δ 0.11 (s, SiMe , 6 H), 0.98 (s, SiCMe_3 , 36 H), 5.45 (s, SiH_2 , 4 H); ¹³C NMR (CDCl_3 , 250 MHz, SiMe_4), δ -7.67 (s, SiCH_3), 21.14 (s, SiCC_3), 28.13 (s, SiCC_3); ²⁹Si NMR (CDCl_3 , 250 MHz, SiMe_4), δ -20.67 (SiH_2 , ¹J_{SiH} = 230.2 Hz), 6.28 (s, SiC).

[§] X-ray structure determination of **4**: data were collected at -140 °C on a Stoe-Siemens-Huber diffractometer with CCD area detector and monochromated Mo-K α radiation ($\lambda = 71.073$ pm). The structure was solved by direct methods.⁹ All non-hydrogen atoms were refined anisotropically.¹⁰ For the hydrogen atoms the riding model was used. The disordered SiH_2 group is refined with distance restraints and restraints for the anisotropic displacement parameters [occupancies: 0.61(2): 0.39(2)]. Crystal data for **4**: $\text{C}_{18}\text{H}_{46}\text{N}_2\text{Si}_4$, $M_r = 402.93$, monoclinic, space group $P2_1/c$, $a = 871.8(2)$, $b = 1236.8(2)$, $c = 1245.9(2)$ pm, $\beta = 107.25(1)^\circ$, $U = 1.2830(4)$ nm³, $Z = 2$, $\rho(\text{calc.}) = 1.043 \text{ Mg m}^{-3}$, $\mu = 0.236 \text{ mm}^{-1}$, 16319 reflections collected of which 2619 were unique ($R_{\text{int}} = 0.0354$); 2619 data and 23 restraints used for the refinement of 139 parameters, $R1 = 0.0396$ for $I > 2\sigma(I)$, $wR2 = 0.1124$ for all data. CCDC reference number 186/1118. See <http://www.rsc.org/suppdata/> dt/1998/2953/, for crystallographic files in .cif format.

Table 1 Calculated and measured geometrical parameters of cyclodisilazane

	Calc.	Calc.	Measured
Si...Si	254.2	249.7	243–245
Si–N (<i>endo</i>)	173.5	174.6	173.4
N–Si (<i>exo</i>)	—	172.4	173.3
Si–N–Si (ring)	94.2	91.3	89.0

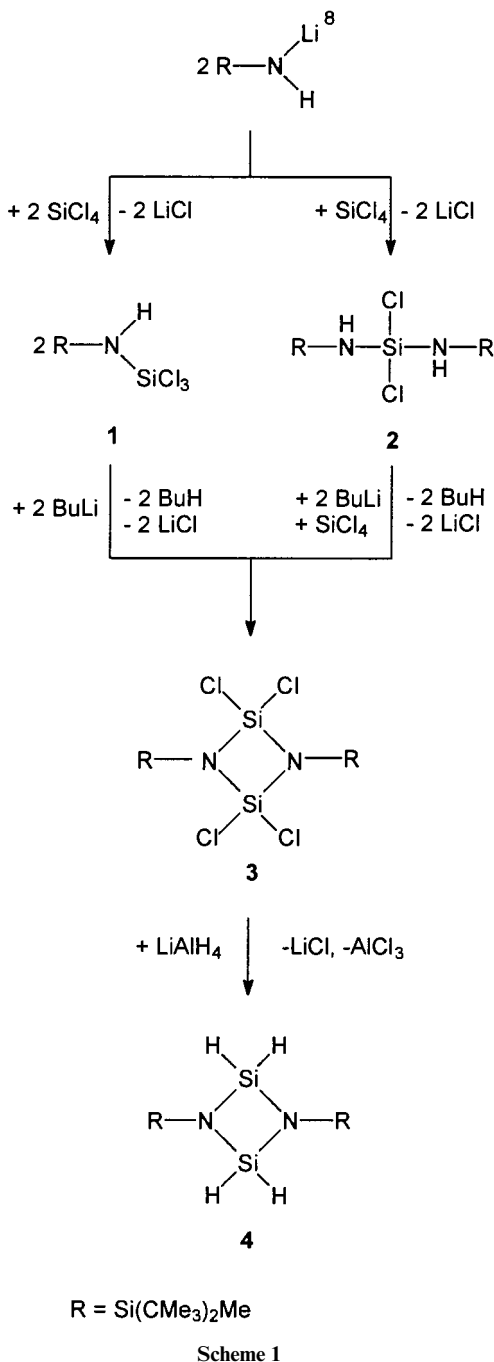

compound **4**; Si–H bonds of 147.4 to 147.8 pm were obtained. It was found that substitution of the hydrogen atoms on the nitrogen atoms by silyl groups decreases the Si–N–Si ring angles

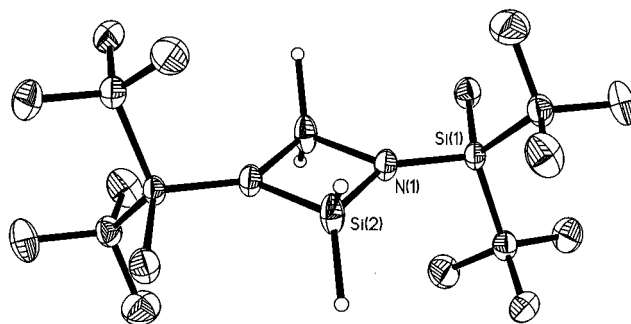

Fig. 1 Molecular structure of compound **4**, selected bond lengths (pm) and angles ($^{\circ}$): Si(2)–N(1) 172.8(4), Si(2)–N(1A) 174.0(4), Si(1)–N(1) 173.3(1); Si(1)–N(1)–Si(2A) 129.3(2), Si(2)–N(1)–Si(1) 140.5(2), Si(2)–N(1)–Si(2A) 89.7(2), N(1)–Si(1)–C(1) 106.4(1), N(1)–Si(1)–C(2) 109.0(1), N(1)–Si(2)–N(1A) 90.3(2).

and therefore shortens significantly the Si...Si distance. The bulkiness of the di-*tert*-butylmethyl groups in **4** explains the discrepancy of 5 pm in the endocyclic Si...Si distance found experimentally in **4**. Important calculated and measured geometrical parameters of cyclodisilazanes (bond lengths in pm; bond angles in $^{\circ}$) are in Table 1.

Acknowledgements

This work was supported by the Fonds der Chemischen Industrie.

References

- J. Haiduc and D. B. Sowerby, *The Chemistry of Inorganic Homo- and Heterocycles*, Academic Press, London, 1987.
- H. Bürger, M. Schulze and U. Wannagat, *Inorg. Nucl. Chem. Lett.*, 1967, **3**, 43.
- B. Tecklenburg, U. Klingebiel, M. Noltemeyer and D. Schmidt-Bäse, *Z. Naturforsch., Teil B*, 1992, **47**, 855.
- T. Müller, Y. Apeloig, I. Hemme, U. Klingebiel and M. Noltemeyer, *J. Organomet. Chem.*, 1995, **494**, 133.
- Ch. Brönneke, R. Herbst-Irmer, U. Klingebiel, P. Neugebauer, M. Schäfer and H. Oberhammer, *Chem. Ber./Recl.*, 1997, **130**, 835.
- J. Niesmann, U. Klingebiel, M. Noltemeyer and R. Boese, *Chem. Commun.*, 1997, 365.
- H. Witte-Abel, U. Klingebiel and M. Noltemeyer, *Chem. Commun.*, 1997, 771.
- L. Ruwisch, U. Klingebiel, S. Rudolph, R. Herbst-Irmer and M. Noltemeyer, *Chem. Ber.*, 1996, **129**, 823.
- G. M. Sheldrick, SHELXS 90, *Acta Crystallogr., Sect. A*, 1990, **46**, 467.
- G. M. Sheldrick, SHELXL 93, University of Göttingen, 1993.
- V. Metall, S. Joanteguy, A. Chrostowska-Senio, G. Pfister-Guillouzo, A. Systemans and J. L. Ripoll, *Inorg. Chem.*, 1997, **36**, 1482.

Received 7th August 1998; Communication 8/06267F